



Prepared by:

[Handwritten Signature]
Signature/Date

Technical Review:

[Handwritten Signature]
Signature/Date

QA Manager:

[Handwritten Signature]
Signature/Date

EPA Review:

[Handwritten Signature]
Signature/Date

STANDARD OPERATING PROCEDURE
FIVE YEAR PLAN (2003 – 2007) WET WEATHER SURVEYS

1.0 Applicability and Scope.

This document covers the field procedures that will be performed during the five planned wet weather surveys per year in the 2004 through 2007 May through October sampling seasons. It is updated yearly to include the final selection of sampling locations in the SWMA(s) sampled in a particular year and any other applicable changes in the monitoring program. Storm Water Management Areas (SWMAs) are planned to be monitored according to the following schedule,

SWMA	2003	2004	2005	2006	2007
Main 1-2		X			
Upper		X			
Middle 1			X		
Middle 3			X		
Lower 1				X	
Lower 2				X	
Main 3-4					X

These procedures will be used to collect water samples, measure dissolved oxygen (DO) and temperature, and record aesthetics at previously selected locations in each SWMA. Each SWMA will have one wet weather sampling location, which is located at the outlet of the SWMA. The only exception is the Main 3-4, which has three wet weather sampling locations. *Table 1* lists the sampling locations by SWMA and *Figure 1* shows their locations.

Sampling will be performed from May through October. Extensions to this range may be necessary and dependent on the event sampled. Five wet weather events will be targeted in each SWMA as shown in the above schedule. Rain events will be targeted so that two small events (0.25 to 0.49 inches), two medium events (0.50 to 0.99 inches), and one large event (greater than or equal to 1 inch) are monitored. At least seven samples will be collected which will adequately define the hydrograph for each event (see figure below). The target will be three samples on the rising limb, two at peak flow, and two on the receding limb of the hydrograph. The project engineer will make the decision as to when samples should be collected and which will be analyzed on an event-by-event basis.

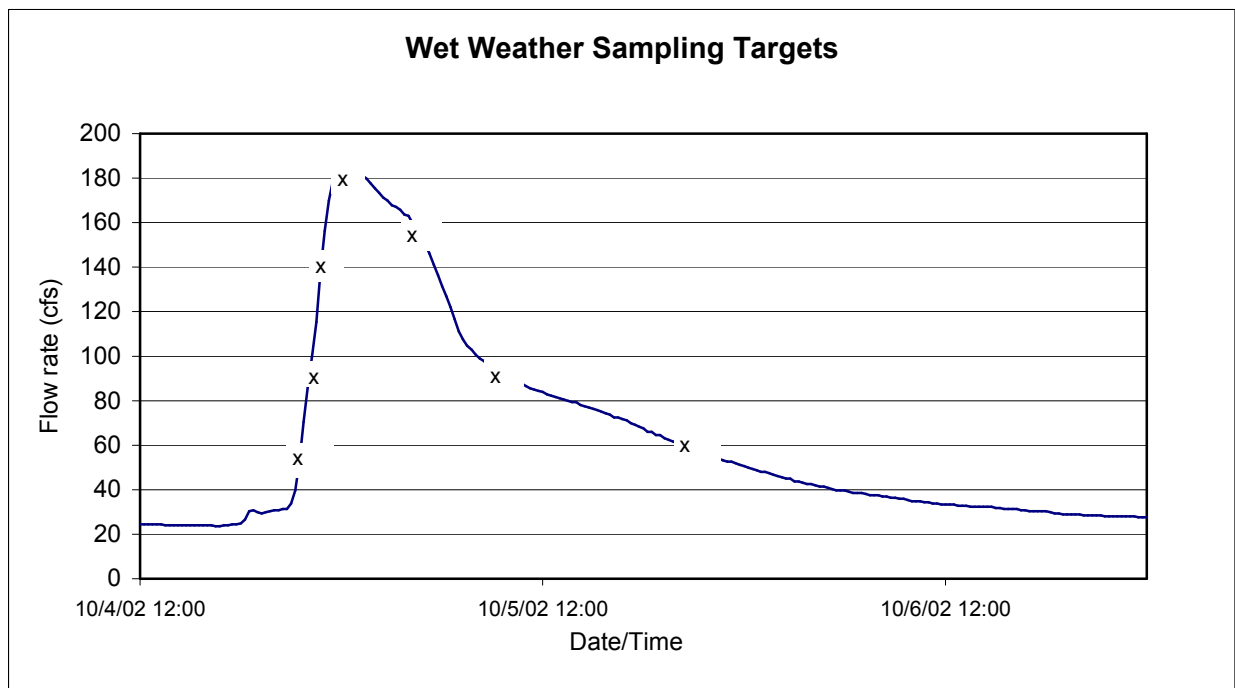

Seasonal variation will be attempted to the extent possible during the wet weather surveys, scheduling permitting. The decision to collect samples is dependent on the river level prior to the rain events. At least 3 days of dry weather prior to the day of the survey is desired. Dry weather is defined as no measurable change in the river level or less than 0.10 inches per day for 48 to 72 hours preceding the event. Coordination with the laboratory and bottle pick-up should occur prior to the wet weather sampling.

The required activities as part of the wet weather survey, at the times determined to define the hydrograph, are to collect grab samples, measure and record DO and temperature, record the staff gage reading (if staff gage present), and record aesthetic observations. Any additional comments that might be applicable to the quality of the sample results should also be recorded. All samples will be delivered to the designated laboratory within the required holding times where they will be analyzed for five water quality parameters: 5-day carbonaceous biochemical oxygen demand (CBOD₅), total suspended solids (TSS), ammonia (NH₃), total phosphorous (P_T), and *E.coli*. *Table 2* summarizes the sampling and laboratory requirements for each parameter.

2.0 Definitions.

Dry Weather Survey – an independent sampling event during which ambient water quality grab samples and/or measurements are taken at predetermined sites throughout the Rouge River watershed during dry flow conditions.

Dry Weather – defined as less than or equal to 0.10 inches per day of rain during a 48 to 72-hour period preceding the dry weather survey or no measurable change in the river level.

Wet Weather Survey – an independent sampling event during which ambient water quality grab samples and/or measurements are taken at a predetermined site(s) within each SWMA of the Rouge River watershed during defined rainfall conditions.

Wet Weather – defined as greater than 0.10 inches per day of rain or measurable change in the river level.

Grab Sample – A single volume of sample collected manually.

3.0 Equipment

The following equipment must be maintained throughout the sampling event:

- Latex gloves
- Safety glasses
- Orange traffic vests
- Traffic cones
- High beam flashlight
- Rain gear
- Cell phone
- Pen with waterproof ink
- Chain of custody forms – Paragon and RTI laboratories

- Sampling bucket and rope
- Cooler
- Distilled water
- Ice
- Field observation worksheet for recording DO, temperature, aesthetics, etc.
- Winkler DO field kit
- Thermometer
- YSI 95 or 550 hand-held DO/Temperature meter (cable will need to be marked off in 1-foot increments for use at Jefferson Ave.)
- Bottle-on-Demand (BOD) sampler (for Jefferson Ave. location only) and 1 L graduated cylinder

In addition, at least seven sets of the following sampling bottles (or as supplied by primary laboratory) are needed per sampling site:

- One bottle (1 L) with no preservative
- One bottle (1 L) with H₂SO₄ preservative
- One 100 ml sterile bottle with no preservative

All QA/QC samples bottles should also be prepared by, and obtained from the primary laboratory, including the bottles for the split samples that will be taken to QC laboratory. All sampling supplies and equipment should be prepared at least one day prior to a forecasted wet weather event.

4.0 Procedures. (Note: the Jefferson Avenue Bridge (M14) site will require a separate set of procedures due to the volume of flow at this location and the backwater effect of the Detroit River. See item 5 below)

Prior to the start of, or at the beginning of a rainfall event, a field team shall proceed to the sampling site and perform the following steps:

1. The field crews will follow the health and safety procedures of their office of employment. See Appendix B. Park the vehicle in a safe location near the sampling site, using traffic control where appropriate. In some locations the shoulder of the road may be minimal and it will be necessary to park the vehicle so that the sampling team is protected from approaching traffic. The vehicle should be parked on the shoulder between traffic and the sampling team. Traffic cones and flashing lights on the vehicle should be used. Orange traffic vests should be worn.
2. **DO/Temperature Measurement.** Complete the Field Observation Worksheet (see Appendix A for example). Record all measurements on this worksheet. **DURING**

RAINFALL THE YSI METERS SHOULD BE PROTECTED IN A CLEAR PLASTIC BAG WHEN MEASUREMENTS ARE TAKEN. IF THE INSTRUMENT GETS WET IT MIGHT GIVE ERRONEOUS RESULTS AND POSSIBLY BE DAMAGED.

- a. See Appendix C for meter setup and operation and LaMotte Kit instructions. Prior to daily use, and anytime the meter is turned off and on, the meter should be calibrated and verified. The LaMotte Winkler kit for DO is used to verify the meter DO and a calibrated thermometer is used to verify the meter temperature. For meter DO measurement to be accepted the meter and Winkler kit should agree to within 0.5 mg/L. If they do not the meter should be recalibrated and/or the Winkler test should be repeated. At times it may be necessary to troubleshoot problems with the meter. A troubleshooting guide is provided in Appendix C. For meter temperature measurement to be accepted the meter and the calibrated thermometer should agree to within 0.5 degrees C.
 - b. Three DO and temperature measurements should be taken at each location whenever possible (on occasion this may be prevented by low flow in the river), at the center of the stream and at left and right one-quarter locations of the stream. All measurements should occur at mid-depth in a well-mixed portion of the stream. At higher flow in the river it may be necessary to attach a weight towards the end of the meter line to prevent the probe from being carried downstream.
 - c. All meter DO readings less than 5.0 mg/L should be verified with the Winkler method.
3. **Sample Collection.** Rinse the sampling bucket twice with distilled water before using at a new location or new time and drain completely.
- a. The bottles should be labeled prior to filling. Often the label will become wet on filling and the pen will not write on the label. Use a waterproof pen to write on the label. The labels will become wet once the bottles are placed in ice. Label each sample with the appropriate Sample ID number (see Appendix A for sample labeling procedure from the RPO Field Sampling Plan). Both bottles are considered ONE sample, and will be labeled with the same Sample ID. However, the analytical tests requested must be indicated on each bottle as follows (or as labeled on the bottles supplied by the laboratory):
 - CBOD₅ and TSS on the 1 L bottle with no preservative.
 - P_T and NH₃ on the 1 L bottle with H₂SO₄ preservative.
 - *E. coli* on the 100 ml sterile bottle with no preservative.
 - b. Obtain samples by lowering the sampling bucket into the stream in a well-mixed portion of the river or stream (nearest to the middle when possible) and at mid-depth (samples should not contain sediment from the bottom or scum from the top), raising the bucket, and carefully pouring the water into the following sample containers:

- One 1 L bottles with no preservative, and
- One 1 L bottle with H₂SO₄ preservative.
(**DO NOT collect** samples in the bottle with preservative directly. If the sample bottle is prepared with preservative **DO NOT overfill** the bottle with sample or the preservative will be diluted.)
- One 100 ml sterile bottle with no preservative.
(The *E.coli* sample should be collected directly into the sterile container. Do not collect a sample for *E.coli* in a non-sterile container unless absolutely necessary. If this is done it must be recorded on the field log and on the Chain of Custody (COC))

All equipment used to obtain grab samples should be rinsed with distilled water after each use.

- c. Record each sample on the COC form (see Appendix A for sample COC form).
 - d. Store all sample bottles in a cooler in ice. The ice should completely surround all sample bottles.
 - e. Estimate the next sampling time that samples will need to be collected at the site and plan to be at the site at the estimated time.
4. **QA/QC Sample Collection.** In addition, duplicate, split and field blank samples shall be taken at sample sites as specified in the Quality Assurance section.
- a. One duplicate and one split sample are to be collected for every one in 20 samples collected. Therefore, duplicates and splits are not necessarily collected during each survey. One field blank is to be collected for each sampling survey.
 - b. Following the collection of all samples and duplicate samples, the sampling team shall transport them to Paragon Laboratories. Split samples shall be delivered to e-Lab Analytical, Inc. courier. All COCs shall be completed (see Appendix A) and signed appropriately and copies returned for filing.
5. **Jefferson Avenue Bridge Sampling.** A composite sample will be developed from grab samples collected at three defined locations across the width of the channel. Flow from the Detroit River on occasion travels up the Rouge River channel above Jefferson Ave. However, complete mixing of the two waters often does not occur. Water samples at Jefferson Ave. will only be collected from selected portions of the cross section that can be attributed to the Rouge River. The selection will be based on readings of temperature and DO. Past sampling has indicated that water from the Detroit River has a lower temperature and higher DO. The Rouge is expected to layer on the top of the Detroit River prior to

mixing because the Detroit River water is denser. Therefore, the grabs will normally be collected in the upper portion of the water column at each of the three sampling locations.

- a. Lower the YSI hand-held meter into the water one foot below the surface. Record the DO and temperature. Lower the probe another 5 feet and record the readings. Continue lowering the probe at 5-foot intervals until a sharp change in readings is measured or the bottom is reached.
- b. Review the recorded data for a sharp change in the recorded data for both parameters or no change at all.
- c. Note the depth where changes start to occur. Grab samples and DO and temperature measurements should be collected and recorded one-third to one-half between the surface and this distance. If no change is seen collect grab samples approximately 10 feet below the water surface.
- d. The BOD sampler will be used to ensure that the samples are collected at the desired depth. Rinse the sampler out with distilled water. Lower the sampler to the desired depth and collect a sample.
- e. Each grab sample at each of the three sites represents one-third of the contents of a sample bottle (determine the volume of the sample bottle and fill appropriately using a graduated cylinder rinsed between uses with distilled water).
- f. Bottle labels should be identified with the time of the first grab sample collected at the first site.
- g. *E. coli* samples may not be collected at this location. This will be determined on an event-by-event basis.

5.0 Health and Safety

All personnel are governed by the rules, regulations, policies, and procedures that have been established by their employer. For these rules, regulations, policies, and procedures each individual must read and is referred to the Health and Safety Manual and officer of their individual employment.

In addition to the guidance of the Health and Safety Manual, field personnel should be aware of the following basic safety issues:

- Traffic Protection – Since some sampling is to be done at or near bridge locations where vehicular traffic may occur, safety precautions to avoid accidents and injury should be observed. The use of traffic cones, vehicle flashing lights, and vehicle placement to protect sampling personnel might be necessary.
- Sampling Location – Some sample sites may require travel through brush and rough or uneven terrain. Appropriate boots and protective clothing should be worn.

- Insects, Rodents and Other Small Animals – Encounters with insects or animals at the sample sites are always a possibility. Field personnel should always keep alerted to their presence to avoid stings or bites. If encounter with one of the above is possible, then insect spray or repellent should be carried.
- Preservatives – Some of the bottles provided by the laboratories contain preservative. Internal and external contact with the preservative should be avoided. Skin and/or eyes may become irritated or burned if exposed to these chemicals. Protective eyeglasses and disposable rubber gloves should be worn while collecting and handling samples. If exposure or contact does occur flush the area with large amounts of distilled water. Perform all sample collection outside of the vehicle to avoid inhalation of fumes. For first aid procedures specific to each method or reagent see the MSDS sheets provided in Appendix B.

All injury accidents should be reported to the sampling coordinator regardless of the extent of the injury.

6.0 Quality Assurance

The quality assurance objective for the wet weather survey is to obtain representative grab samples at each sample location.

One duplicate and one split sample shall be taken for every one in 20 samples collected (i.e. two duplicates and two splits required for 21 samples). One field blank sample shall be collected per survey.

1. A duplicate sample is an additional sample (two bottles for each parameter) taken at any given sample site that is also sent to the primary laboratory and is recorded on the same primary laboratory COC. The sample shall be given a Sample ID according to the attached sample labeling procedure.
2. A split sample is an additional sample (two bottles for each parameter), taken at the same site as the duplicate that is sent to the QC laboratory and is recorded on a separate QC laboratory COC. The sample shall be given a Sample ID according to the attached sample labeling procedure.
3. A field blank sample is an additional sample taken at any given sample site that is filled with distilled water. Field blanks are delivered to the primary laboratory.

An original sample, a duplicate sample, and a split sample shall all be taken at the same sample site. **All samples for the same parameter should come from the same volume of the sampling bucket (i.e. raise the sampling bucket from the river and fill the non-preserved bottle from the original, duplicate and split sample; obtain another sample from the river**

and fill the bottle with H₂SO₄ preservative for each of the three samples). If any settling has occurred in the collection bucket, it should be thoroughly mixed before distributing into the sample containers. This is to ensure that the unique water sample being used for comparison is the same for each analytical test.

The field blank sample bottles shall be filled with distilled water at the sample site following collection of the original sample. The bottles shall be handled and processed as if they were an actual sample.

7.0 Personnel

Field sampling and monitoring shall be performed using a two-person crew. Since wet weather events are expected to last several hours, to days, it might be necessary to have replacement crews to continue sampling. Other field survey personnel include the sampling coordinator, the project manager, and the two laboratory contacts. Table 3 is a list of all personnel involved in the project and includes contact information.

Table 1
Wet Weather
2003 – 2007 SWMA Sampling and Monitoring Locations
(Within SWMA, station order is upstream to downstream.)

SWMA	Field ID	Site ID	Location Description
Main 1-2	US5	M1007261	Beech Road
Main 3-4	G43	M2003543	5 Mile Road, W. of Lahser Road
	US7	M2003045	Plymouth Road
	US8	M3009637	Rotunda Dr.
Lower 1	US9	L2009638	Hannan Road
Lower 2	L05D	L2009355	Military Road
Middle 1	US10	D2009639	Haggerty Road
Middle 3	D06	D3003526	Hines/Ford Road
Upper	U05	U1003575	Telegraph Road

Table 2
Sample and Laboratory Requirements
(Bottles with preservative are supplied by Primary Laboratory)

Parameter	Bottle Type	Bottle Volume	Preservative	Hold Time	Laboratory
CBOD ₅	Polyethylene	1 L	None	48 hours	Primary (splits to QC Laboratory)
TSS			None	48 hours	
NH ₃	Polyethylene	1 L	H ₂ SO ₄	48 hours	
P_T			H ₂ SO ₄	48 hours	
<i>E.coli</i>	Polyethylene	100 ml sterile	none	6 hours	

**Table 3
Contact Information**

Titles/Roles	Name	Office Phone	Office Fax	Pager / Cell	Home Phone
Work Plan Manager	Colleen Hughes, CDM	(734) 213-5444	(734) 213-5775	(734) 353-0138	
Monitoring Task Manager	Chris Catalfo, CDM	(734) 326-3936	(734) 326-4421		(734) 453-1023
Monitoring Technical Advisor	Ed Kluitenberg, CDM	(734) 213-5444	(734) 213-5775	(734) 476-1108	(734) 485-5714
Wayne County Department of Environment	Patrick Cullen Sue Thompson Noel Mullett Matt Best	(734) 326-3936 (734) 326-3926 (734) 326-3936 (734) 326-3926	(734) 326-4421 (734) 326-4421 (734) 326-4421 (734) 326-4421	(313) 999-6267 (313) 999-6266 (313) 999-6260 (313) 999-6264	
Applied Science Inc.	Andy Wood	(313) 567-3990	(313) 567-3750	(517) 214-1621	(734) 812-4979
Paragon Laboratory	John Spurr	(734) 462-3900	(734) 462-3911		
e-Lab Analytical, Inc.	Ann Preston	(616) 399-6070 x 525	(616) 399-6185	(616) 218- 5574	

Figure 1

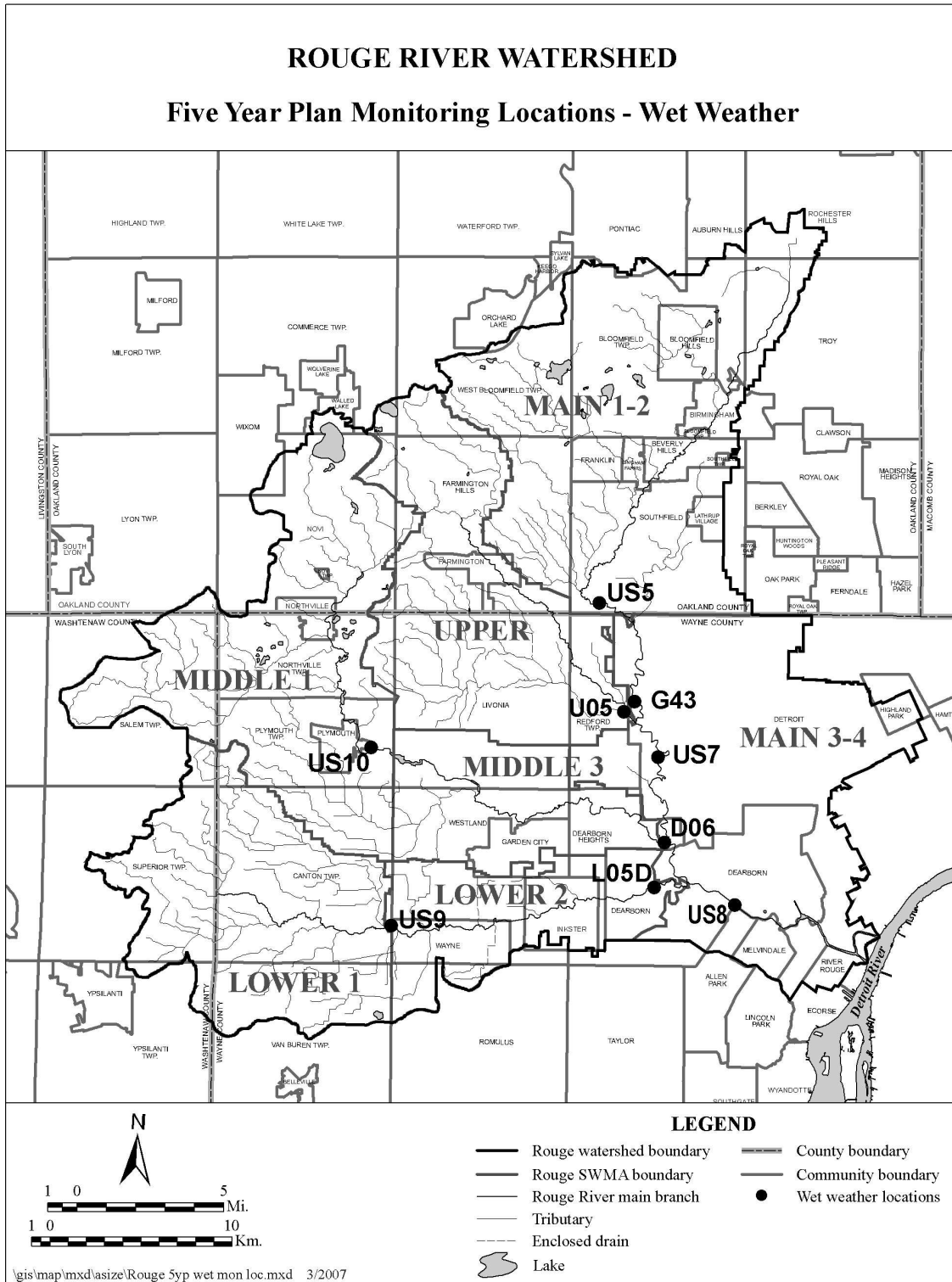

Appendix A
Labels and Forms

FORM 208B
FIELD OBSERVATION WORKSHEET
AESTHETICS AND DO

TIME 12:20
RECORD 20-2
DATE 6/6
SAMPLER THE RAINOUT CR

Crew JHC/ST

FIELD ID	Date	Time	Reading #	Weather			METEOROLOGICAL Measurements (mmHg, C)			Wind Dir	Wind Spd	Water Clarity			Water Color			Color			Dobson			Comments/Questions/Problems
				Rain	Fog	Cloud	Temp	DO	Temp			Temp	Temp	Temp	Temp	Temp	Temp	Temp	Temp	Temp	Temp	Temp	Temp	
015	6/6/20	1:51				X	6.5	10.0	6.6	20.0	6.6	20.0	6.4	1.4	X	X	X	X	X	X	X	X	X	PARTIAL PLASTIC BAGS AND SAMPLES.

Sample Designation. All sample bottles should be pre-labeled on the bottle, not the cap, to identify the sample for laboratory analysis. Sample labels should include type of sample (grab or composite), Sampler's name, date, time, and location. Sample identification will use the following format:

Sample Numbering Scheme:

SSSYMMDDHHmmTTT

Where:

- SSS = Station Number/Location Identifier
(Can be up to 8 identifiers, typically 3-4) Example G45 Maple, G461 14 Mile @ Franklin.
- Y = Last digit of Year
- MM = Month two digits (01-12)
- DD = Day two digits (01-31)
- HH = Hour (Military Time) two digits (01-24)
- mm = Minute two digits (00-59)
- TTT = Type of sample (Note: ## denotes sample number, series, or set)
 - G## = Grab Water Sample
 - A## = Automatic Sampler Water Sample
 - S## = Soil/Sediment Sample
 - L## = Landfill/Leachate Sample
 - #81 = Field Duplicate
 - #86 = Field Blank
 - #87 = Split Sample

Example: L05806081025G00

This sample is from monitoring site number L05 (Military Rd.), collected on June 8, 1998. It is a grab sample taken at 10:25 a.m.

Example: G91806130330G87

This sample is from grab sampling site G91 (Venoy Road), collected on June 13, 1998. It is a quality control split sample taken at 3:30 a.m.

The chain-of-custody form has a column for indicating the sample designation. It is very important that the number is entered correctly.

CHAIN-OF-CUSTODY RECORD



12649 Richfield Court • Livonia, MI 48150 • (734) 462-3900 • Fax (734) 462-3911

Client Name: WAYNE COUNTY DEPT. OF ENVIRONMENTAL		Checked By:		
Contact Person: DEAN TUOMARI / CHRIS CATALAN		Sample Condition Upon Receipt: Acceptable Other (Specify below)		
Mailing Address: WCDOE WMD 3600 COMMERCE CT		Volatiles Preserved: Yes No Metals ff: Yes No pres: Yes No		
City, State, Zip Code: WAYNE MI 48184		Remarks:		
Phone: 326 3936 Fax: 734 324-4421		ANALYSIS REQUESTED		
Client Job Name/No.: ROUGE NWWDP		C6 DBS TSS NH3 E. Coli		
Job Loc: ROUGE INSTREAM		PARAGON SAMPLE NO.		
Sampled By: CHC P.O. No.:		Possible Health Hazard		
Regulatory Requirements: <input type="checkbox"/> MERA TMDLs <input type="checkbox"/> RCRA <input type="checkbox"/> NPDES <input type="checkbox"/> Drinking Water Other:		Turnaround Requirements: <input checked="" type="checkbox"/> Standard 5-7 DAY <input type="checkbox"/> 2 Day (RUSH) <input type="checkbox"/> 24 Hour (RUSH) <input type="checkbox"/> SPECIAL		
Matrix Key: S = Soil W = Water O = Oil SL = Sludge A = Air X = Other		NUMBER OF CONTAINERS: MATRIX		
DATE TAKEN: 01/15/03 TIME TAKEN: 11:20 GRAB: X COMP:	CLIENT SAMPLE ID: 645309151420 MATRIX: W3	EX AM PV E		
Trans #	RELEASED BY	RECEIVED BY	DATE	TIME
1)	C.H. Catala		01/15/03	16:20
2)				

Appendix B

Health and Safety Information

Refer to the Health and Safety Manual and Officer of Individual Employment

Appendix C

YSI 95 Meter Operation YSI 550 Meter Operation LaMotte Winkler Kit and MSDS sheets

YSI Incorporated Model 95

PREPARING THE METER BATTERIES

There are a few things you must do to prepare your YSI Model 95 for use. First, locate the six AA-sized alkaline batteries that were included. Use a screwdriver or a small coin to remove the thumbscrew on the bottom of the instrument (see figure below). This thumbscrew holds the battery chamber cover in place. The battery-chamber cover is marked with the words "OPEN" and "CLOSE."

NOTE: On some models, the battery cover thumbscrew may be unscrewed by hand (a screwdriver may not be required).

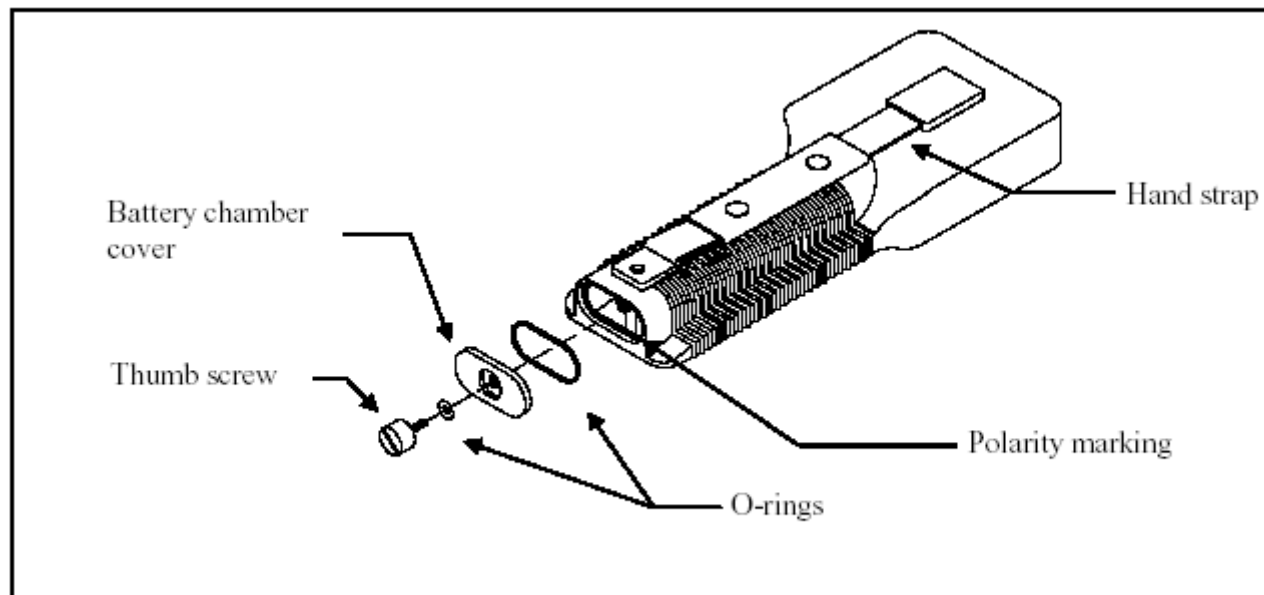

There is a small molded insert inside each of the two battery-chamber sleeves. These labels illustrate the correct way to install the batteries into each sleeve of the battery-chamber. **CAUTION:** It is very important that the batteries be installed ONLY as illustrated. The instrument will not function and may be damaged if the batteries are installed incorrectly.

Turn the instrument on by pressing and releasing the **ON/OFF** button on the front of the instrument. The liquid crystal display (LCD) should come on. Allow a few seconds for the instrument to complete its diagnostic routine. If the instrument does not operate, consult Section 8, **Troubleshooting**.

You may also want to take the instrument into a dark room and with the instrument ON, hold down the **LIGHT** button. The instrument back light should illuminate the LCD so that the display can be easily read.

CALIBRATION/STORAGE CHAMBER

The Model 95 has a convenient calibration/storage chamber built into the instrument's side. This chamber provides an ideal storage area for the probe during transport and extended non-use. If you look into the chamber, you should notice a small round sponge in the bottom. Carefully put about 10 drops of clean water into the sponge. Turn the instrument over and allow any excess water to drain out of the chamber. The wet sponge creates a 100% water saturated air environment for the probe that is ideal for dissolved oxygen calibration. Figure 1.

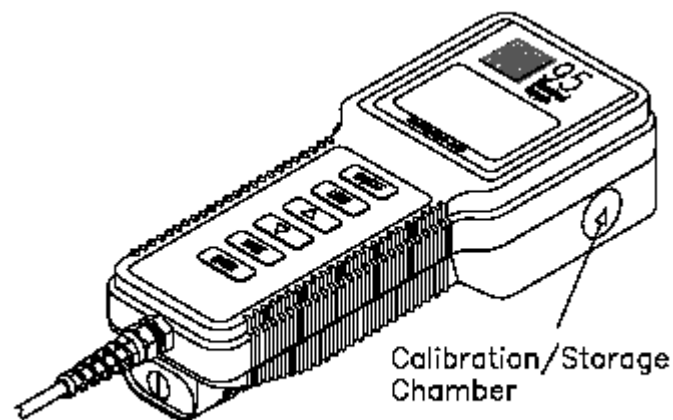

Figure 1

HAND STRAP

The hand strap (see figure on previous page) is designed to allow comfortable operation of the Model 95 with minimum effort. If the hand strap is adjusted correctly, it is unlikely that the instrument will be easily dropped or bumped from your hand. To adjust the hand strap on the back of the meter, unsnap the vinyl cover and pull the two Velcro strips apart. Place your hand between the meter and the strap and adjust the strap length so that your hand is snugly held in place. Press the two Velcro strips back together and snap the vinyl cover back into place.

METER CASE

The meter case is sealed at the factory and is not intended to be opened, except by authorized service technicians. **Do not attempt to separate the two halves of the meter case as this may damage the instrument, break the water-proof seal, and may void the manufacturer's warranty.**

PREPARING THE PROBE

The YSI Model 95 dissolved oxygen probe is shipped wet with a shipping membrane installed. This protective membrane cap on the probe tip must be removed and replaced with a new membrane cap filled with MEA probe solution before using the probe. Follow the instructions below to install the new membrane cap.

CHOOSING THE CORRECT MEMBRANE CAP

Two different membrane caps are available for the Model 95. The **YSI Model 9501 Membrane Cap Kit** is supplied with the Model 95. This kit contains six 0.5 mil (.0005") membrane caps and a bottle of MEA probe solution (KCl). **NOTE:** YSI 9501 Membrane Caps offer the fastest response to changes in DO and are recommended by YSI for most applications. For conditions with low flow or stagnant water, a 1 mil (.001") membrane is available (YSI Model 9502 Membrane Cap Kit). This membrane requires less stirring than the 9501, but has a much slower response. Use this membrane when minimal stirring (<2"/sec) is available.

MEMBRANE CAP INSTALLATION

WARNING: Use only YSI MEA probe solution in the membrane cap. Any other solution will damage the MEA sensor. To install a new membrane cap on your YSI Model 95 dissolved oxygen probe:

1. Unscrew and remove the probe sensor guard (see Figure 2).
 2. Unscrew and remove the old membrane cap.
 3. Thoroughly rinse the sensor tip with distilled water.
 4. Hold the membrane cap and add 8 to 9 drops of MEA probe solution (about half full).
 5. Tap the bottom of the cap with your finger a few times to remove any trapped air bubbles.
- CAUTION: Do not touch the membrane surface.**
6. Screw the membrane cap onto the probe tightly by hand (to prevent leakage of electrolyte). A small amount of probe solution should overflow.
 7. Shake off any excess probe solution and rinse the stainless steel thoroughly with distilled water to prevent corrosion.

Preparing the Probe Section 3

YSI Incorporated Model 95 5

WARNING: Use only YSI MEA probe solution in the membrane cap. Any other solution will damage the MEA sensor.

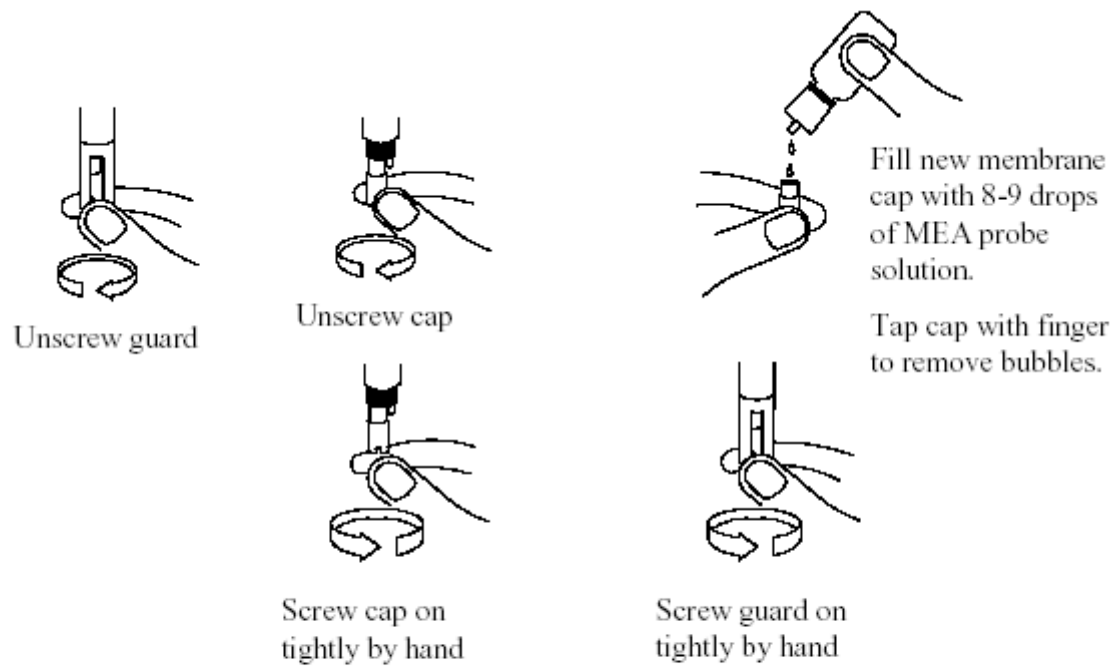

Figure 2

OPERATION - The following diagram is an overview of the operation of the Model 95. See the following sections for details of operation.

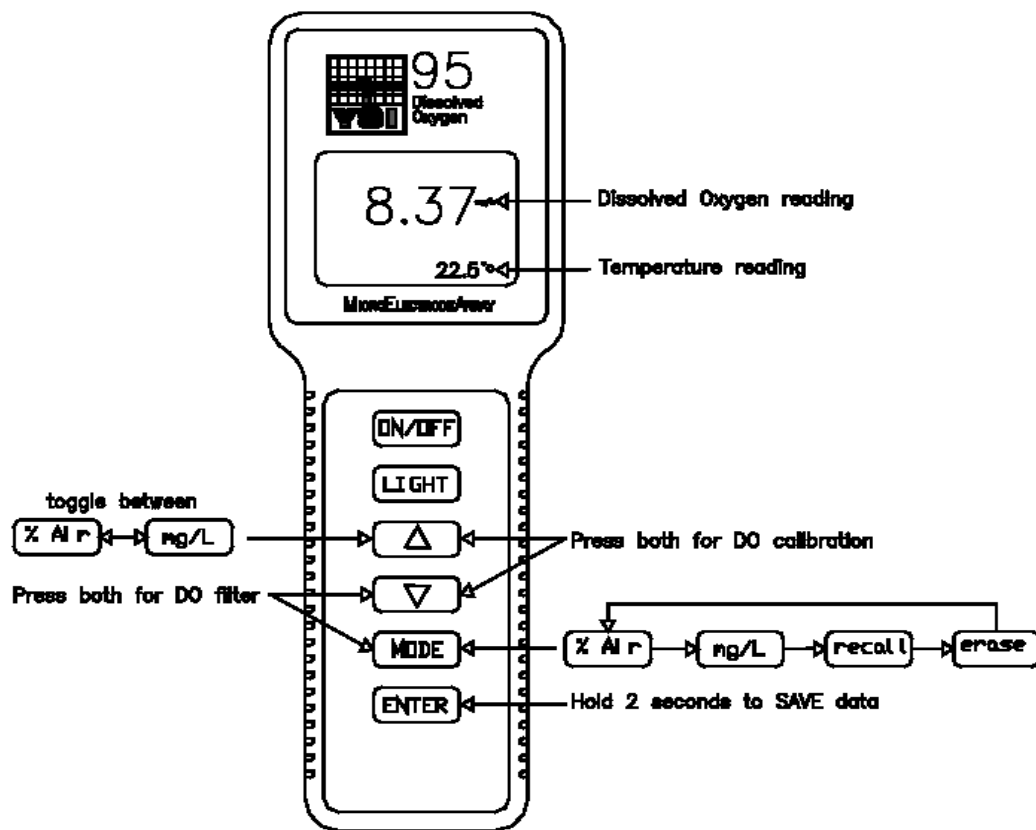

Figure 3

OPERATION

TURNING THE INSTRUMENT ON

With the batteries installed correctly, press the **ON/OFF** button. The instrument will activate all segments of the display for a few seconds, which will be followed by a self test procedure which will last for several more seconds. During this power on self test sequence, the instrument's microprocessor is verifying that the system is working properly. If the instrument were to detect a problem, a **continuous** error message would be displayed. See the section entitled *Troubleshooting* for a list of error messages. **NOTE: It is normal for an error to be displayed for a second or two when the system is first turned on.**

CALIBRATION

Dissolved oxygen calibration must be done in an environment with a known oxygen content. Since the amount of oxygen in the atmosphere is known, it makes an excellent environment for calibration (at 100% relative humidity). The calibration/storage chamber contains a moist sponge to create a 100% water saturated air environment.

Before calibrating the YSI Model 95, complete the procedures discussed in the *Preparing the Meter and Preparing the Probe* sections of this manual.

To accurately calibrate the YSI Model 95 you will need to know the following information:

- The approximate altitude of the region in which you are located.

The approximate salinity of the samples that you will be measuring. **Fresh water has a salinity of approximately zero.**

1. Ensure that the sponge inside the instrument's calibration chamber is wet. Insert the probe into the calibration chamber.
2. Turn the instrument on by pressing the **ON/OFF** button. Wait for the dissolved oxygen and temperature readings to stabilize (usually 15 minutes is required after turning the instrument on). If the instrument was already on, press the **MODE** button until dissolved oxygen is displayed in mg/L or % air saturation. To enter the calibration menu, use two fingers to press and release both the **UP ARROW** and **DOWN ARROW** buttons at the same time (**DOWN ARROW** slightly ahead).

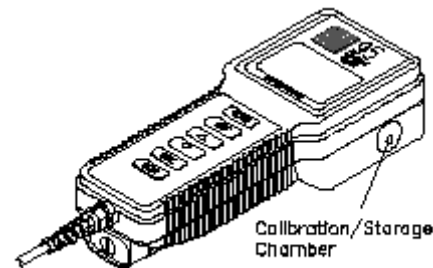

Figure 4

3. The LCD will prompt you to enter the local altitude in hundreds of feet. Use the arrow keys to increase or decrease the altitude. When the proper altitude appears on the LCD, press the **ENTER** button once. **EXAMPLE:** Entering the number 6 here indicates 600 feet.
4. The LCD will prompt you to enter the salinity of the sample(s) that you will be measuring. You can enter any number from 0 to 80 (ppt). Use the arrow keys to increase or decrease the salinity setting. When the proper salinity appears on the LCD (zero for fresh water), press the **ENTER** button.
5. The Model 95 should now display **CAL** in the lower left of the display, the calibration value should be displayed in the lower right of the display and the current DO reading (before calibration) should be on the main display. Make sure that the DO reading (large display) is stable, then press the **ENTER** button. The display should read **SAVE** then should return to the Normal Operation Mode.

For best results:

- Each time the Model 95 is turned off, re-calibrate before taking measurements.
- Calibrate at a temperature within 10°C of the sample temperature.

MAKING MEASUREMENTS

The Model 95 has four modes:

_ **Dissolved Oxygen %** -- A measurement of oxygen in percent of air saturation (partial pressure).

_ **Dissolved Oxygen mg/L** -- A measurement of oxygen solubility in mg/L.

_ **Recall** -- Allows previously stored data to be displayed.

_ **Erase all** -- Allows ALL previously stored data to be deleted.

Temperature is displayed in both dissolved oxygen modes.

NOTE: When you turn the Model 95 off, it will “remember” which DO mode you used last and will return to that mode the next time the instrument is turned on. To change between the Model 95 modes, simply press and release the **MODE** button. The Model 95 will cycle through the modes as follows: Dissolved Oxygen in % with °C, Dissolved Oxygen in mg/L with °C, Recall, Erase all.

STIRRING

It is important to realize that even a small amount of stirring will improve the DO and temperature response times in stagnant water, because the transfer process of heat and oxygen will be facilitated by convection. Also, the MEA dissolved oxygen probe is not totally stirring independent due to the consumption of oxygen at the sensor tip during measurement. When taking dissolved oxygen measurements in totally stagnant samples, the probe must be moved through the sample at a rate of 2 inches per second to provide adequate stirring.

TOGGLING BETWEEN %-AIR SATURATION AND MG/L

The **UP ARROW** key allows quick and convenient switching between the two DO parameters without going through the instrument’s four modes (using the **MODE** key). Press the **UP ARROW** key to toggle the DO reading between %-air saturation and mg/L.

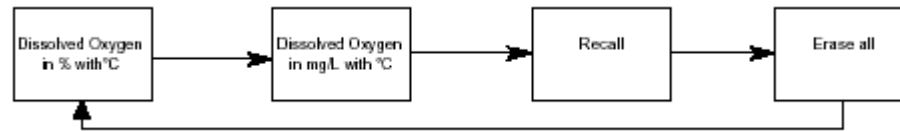

DISSOLVED OXYGEN FILTER

The Model 95 is equipped with a DO filter to help filter out instability and high frequency noise. This feature is useful when measuring dissolved oxygen in an unstable environment such as a fast moving stream or an aeration tank. The default option for the filter is off. To activate the filter, enter the filter option menu by pressing both the **DOWN ARROW** and **MODE** keys together (_ key slightly ahead).

Operation procedures:

- . Press both the **DOWN ARROW** and **MODE** keys together (_ key slightly ahead). The current status of the filter is displayed, **On** or **OFF**, with a smaller “**FIL**” displayed in the bottom right corner of the screen.
- . Press the **UP ARROW** or **DOWN ARROW** key to change the current status of the filter option.
- . Press **ENTER** to confirm the change.
- . To abort any changes and exit the filter menu, press the **MODE** key (instead of **ENTER**).

DISPLAY BACKLIGHT

At times it may be necessary to take measurements with the Model 95 in dark or poorly lit areas. To help in this situation, the Model 95 comes equipped with a backlight that will illuminate the display so that it can be easily read. To activate the backlight, press and hold the **LIGHT** button. The display will remain lit as long as the button is depressed. When you let it up, the light goes out to preserve battery life. On **FIL**

MEA CLARK OXYGEN SENSOR

The MEA (microelectrode array) is a steady-state Clark type polarographic (voltammetric) dissolved oxygen sensor. The sensor is made of a silver anode and a gold cathode (consisting of 100 very small electrodes, each measuring approximately 8 micrometers in diameter) and is separated from the measured medium by a semi-permeable Teflon membrane. The small dimensions of each individual micro surface consume a very small amount of oxygen. Large spacing between adjacent microspheres allows for minimal overlap of diffusion layers from adjacent cathode surfaces. This design produces the minimal stirring dependence of the MEA probe. The temperature sensing element (thermistor assembly) is mounted next to the oxygen sensor vertically (see Figure 1), providing temperature readings for the DO system. The membrane selectively allows oxygen to permeate into the sensor, but prevents most interfering molecules and fouling materials from entering. Upon permeating through the membrane, oxygen is reduced at the gold cathode. The current resulting from this reduction is diffusion-limited and is proportional to the partial pressure of oxygen in the sample. The counter reaction is the oxidation of silver at the anode/reference electrode that completes the overall electrolytic reaction in the chloride medium (KCl electrolyte) behind the membrane. These reactions, at the cathode and the anode, are as follows:

Cathode reaction:

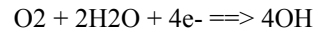

Anode reaction:

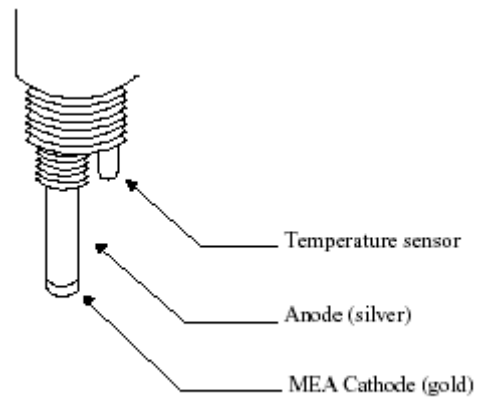
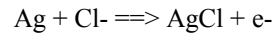

Figure 5

DO READINGS FROM THE CATHODE REDUCTION

The oxygen reduction current is sampled and processed, by the meter, and displayed as either %-air saturation or mg/L. While the parameter of %-air (partial pressure) is independent of temperature and salinity, mg/L (solubility of oxygen) is a function of temperature and salinity. The same %-air reading (same partial pressure) would give a higher mg/L reading at a lower temperature than at a higher temperature. The higher the salinity, the lower the solubility (mg/L) is for the same %-air reading at the same temperature.

FORMATION OF AgCl AT THE ANODE

While the oxygen reduction current passes through the internal circuit to be reported as the DO reading, it also passes through the anode oxidizing the silver and forming a thin layer of silver chloride. Furthermore, the oxidation of silver at the chloride medium provides a stable potential that the cathode potential is referenced to (for instance, the polarization potential of the cathode is -1.0 V versus the potential of the Ag/AgCl redox couple at the silver anode). Since the current of the MEA sensor is so small, there should not be any significant accumulation of AgCl at the anode for 3 to 4 years.

FUNCTION OF THE EL ELECTROLYTE

There are two main functions for the electrolyte:

1. Supply the chloride (Cl-) to the anode/reference electrode for the counter reaction of the oxygen reduction at the cathode.
2. Provide the ionic conduction of electricity inside the cell, especially in the thin layer between the gold cathode and the membrane.

Under normal operating conditions, such as measuring oxygen around 100%-air saturation (8.27 mg/L) at 25°C, the electrolyte should last up to 500 hours. This translates into about 62.5 working days at 8 hours per day operation. The actual electrolyte life, however, may be shorter since, in most environmental applications, membrane fouling determines the life of the electrolyte/membrane.

ANODE SERVICE

Warning: Under no circumstances should ammonium hydroxide be used to clean the silver anode. Ammonium hydroxide will permanently damage the condition of the MEA surface.

The MEA oxygen sensor is, in principle, the same as the conventional Clark oxygen sensor in that the sensor is made of a silver anode and a gold cathode, but the cathode is a microelectrode array. Since the current of the MEA oxygen sensor is so much smaller (on average 100 times smaller) than the current of YSI conventional oxygen sensors, consumption of the silver anode, due to the formation of AgCl, is minimal during the lifetime of the probe. There should not be any significant build-up of silver chloride at the surface of the anode for 3 to 4 years, therefore, the anode should not require chemical cleaning. However, if the surface of the silver anode has become fouled, gently wet sand it using 400 grit wet/dry sandpaper, rinse thoroughly with deionized or distilled water and wipe with a wet paper towel until the dark layer is removed. The directions are as follows:

Anode Cleaning Procedures (See figure 6)

- _ Rinse the sensor thoroughly after removing the membrane cap.
- _ Use wet 400 grit sandpaper to sand away the top layer of the anode by wrapping the sandpaper around the anode and gently rotating it until the dark layer is removed.
- _ Rinse the anode thoroughly with deionized or distilled water and wipe with a wet paper towel.
- _ Rinse the anode again with deionized or distilled water.

Cathode Anode

Press lightly against sensor surface. Wet microcloth Buffing Tool.

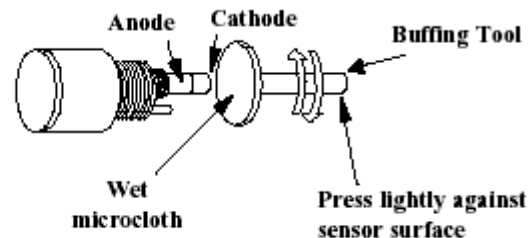

Figure 6

CATHODE SERVICE

Warning: Under no circumstances should the gold cathode surface (the MEA surface) be sanded. Sanding will permanently damage the condition of the MEA surface. If the MEA oxygen sensor exhibits erratic behavior, such as a current rise at a rate of 1%/hour or very jumpy readings, it can be serviced by buffing. You can use a few light twists against the surface with the wet microcloth mounted on the buffing tool provided in the 9503 reconditioning kit.

Note: The MEA sensor does not require buffing (cleaning) every time the membrane cap is changed. Under normal operating conditions, the MEA sensor should be buffed no more than two times per year.

Cathode Cleaning Procedures

- _ Remove the membrane cap and rinse the sensor thoroughly with deionized or distilled water.
- _ Place the microcloth on the buffing tool (self-adhesive). Wet the microcloth thoroughly with deionized or distilled water.
- _ Twist the buffing tool back and forth three times in opposite directions while lightly pressing the buffing tool against the sensor surface (see figure 6).
- _ Rinse the sensor surface well with deionized or distilled water after buffing.

DISSOLVED OXYGEN PROBE PRECAUTIONS

Membrane life depends on usage. If the probe is properly maintained, one membrane cap should last two to four weeks depending on how often the probe is used and the type of samples measured. It is recommended that membrane caps not be re-used.

1. To keep the electrolyte from drying out, store the probe in a moist environment, such as the calibration chamber with the wet sponge inside.
2. Erratic readings are a result of loose, wrinkled, damaged, or fouled membranes, or from large (more than 1/4 of the circumference of the probe) bubbles in the electrolyte reservoir. If erratic readings or evidence of membrane damage occurs, you should replace the membrane cap and the KCl solution. The average replacement interval is two to four weeks.
3. If the membrane is coated with oxygen consuming (e.g. bacteria) or oxygen evolving organisms (e.g. algae), erroneous readings may occur.
4. Chlorine, sulfur dioxide, nitric oxide, and nitrous oxide can affect readings by behaving like oxygen at the probe. If you suspect erroneous readings, it may be necessary to determine if these gases are the cause.

5. Avoid any environment that contains substances that may attack the probe materials. Some of these substances are concentrated acids, caustics, and strong solvents. The probe materials that come in contact with the sample include FEP Teflon, stainless steel, epoxy, polyetherimide and the polyurethane cable covering.
6. Do not allow the probe to strike hard objects. The membrane or sensor inside may be damaged.

PROBE STORAGE

For long term storage (4 weeks), remove the membrane cap, thoroughly rinse the MEA sensor with deionized or distilled water and install a new membrane cap filled with MEA probe solution. Store the sensor in a humid environment such as the calibration chamber with the wet sponge inside. Do NOT store the probe dry.

DISCUSSION OF MEASUREMENT ERRORS

There are three basic types of dissolved oxygen errors. Type 1 errors are related to limitations of instrument design and tolerances of instrument components. These are primarily the meter linearity and the resistor tolerances. Type 2 errors are due to basic probe accuracy tolerances, mainly background signal, probe linearity, and variations in membrane temperature coefficient. Type 3 errors are related to the operator's ability to determine the conditions at the time of calibration. If calibration is performed against more accurately known conditions, type 3 errors are appropriately reduced.

Type 1 Errors

- A. Meter linearity error: $\pm 0.5\%$ of full scale reading, or ± 0.04 mg/l at 25°C whichever is greater.
- B. Component and circuitry error: ± 0.04 mg/l

Type 2 Errors

- A. DO errors caused by temperature compensation for measurements at $\pm 10^{\circ}\text{C}$ from calibration temperature: $\pm 1\%$ of 25°C (± 0.08 mg/l)
- B. DO errors caused by temperature measurement errors: A maximum $\pm 0.2^{\circ}\text{C}$ temperature error is equal to $\pm 0.5\%$ (0.04mg/L at 25°C).

Type 3 Errors

- A. Altitude: The maximum DO error caused by calibrating to altitude in increments of 100 feet: $\pm 0.18\%$ (< 0.015 mg/l at 25°C)
- B. Humidity: Errors occur if calibration is performed at less than 100% humidity. The worst possible case would be calibration at 0% humidity. The error varies with the calibration temperature as follows:

Temperature	Calibration Error at 0% humidity
0°C	0.09 mg/l
10°C	0.14 mg/l
20°C	0.21 mg/l
30°C	0.33 mg/l
40°C	0.50 mg/l

Approximating The Error

It is unlikely that the actual error in any measurement will be the maximum possible error. A better error approximation is obtained using a root mean squared (r.m.s.) calculation:

$$\text{r.m.s. error} = \pm[1a^2 + 1b^2 + 2a^2 + 2b^2 + 3a^2 + 3b^2]^{1/2} \text{ mg/l}$$

NOTE: This calculation is for a near extreme set of conditions.

If the probe is calibrated in water-saturated air, then type 3B errors (humidity), the largest error of all types, is virtually eliminated and the maximum possible error is in the order of 0.1 mg/L for the case of calibrating around 25°C.

TROUBLESHOOTING

Symptom

1. Instrument will not turn on

Possible Cause

- A. Low battery voltage
- B. Batteries installed wrong
- C. Meter requires service

Action

- A. Replace batteries (Section 2)
- B. Check battery polarity. (Section 2)
- C. Return system for service (Section 9)

2. Instrument will not calibrate

- A. Membrane is fouled or damaged

- A. Replace membrane cap (Section 3)

	B. Probe anode is fouled or dark C. Probe cathode is fouled D. System requires service	B. Clean anode (Section 6) C. Buff cathode (Section 6) D. Return system for service (Section 9)
3. Instrument "locks up"	A. Instrument has rec'd a shock B. Batteries are low or damaged C. System requires service	A & B. Remove battery lid, wait 15 seconds for reset, replace lid. (Section 2) C. Return system for service (Section 9)
4. Dissolved Oxygen readings are inaccurate	A. Cal altitude is incorrect B. Probe not in 100% water saturated air during Cal procedure C. Membrane fouled or damaged D. Probe anode is fouled or dark E. Probe cathode is fouled F. System requires service	A. Recalibrate w/correct value (Section 4) B. Moisten sponge & place in Cal chamber w/ probe & Recal (Section 4) C. Replace membrane cap (Section 3) D. Clean anode (Section 6) E. Buff cathode (Section 6) F. Return system for service (Section 9)
5. LCD displays "LO BAT"	A. Batteries are low or damaged	A. Replace batteries (Section 2)
6. Main Display reads "OVER" (Secondary display reads "ovr") (Secondary display reads "udr")	A. Temperature reading is >45°C B. Temperature reading is <-5°C C. DO temperature is >45°C D. DO % saturation is >500% E. DO concentration is >50 mg/L F. Probe current too high to calibrate	In all cases, check calibration values and procedures. (Section 4) If each of these were done correctly, return instrument for service. (Section 9)
7. Main display reads "PErr" instruction for the function you are attempting.	A. Incorrect sequence of keystrokes.	A. Refer to manual section for step by step
8. Main display reads "Err" (Secondary display reads "ra")	A. System has failed its RAM test check procedure. B. Return the system for service (Section 9)	A. Turn instrument OFF and back ON again
9. Main display reads "Err" again.	A. System has failed its ROM test check	A. Turn instrument OFF and back ON

(Secondary display reads “ro”)

procedure.
B. Return the system for service (Section 9)

10. Main reads “Undr” Probe current too low to calibrate

A. EEPROM has failed to respond in time.

10. Main display reads “FAIL”
(Secondary display reads “eep”)

A. Return the system for service (Section 9)

11. Readings on main display don’t change

A. Meter is in recall mode.

A. Press MODE button to return to Normal Operation (Section 4)

FIELD OPERATION GUIDE YSI 550 DO INSTRUMENT

TURNING THE INSTRUMENT ON

The YSI 550 DO keypad consists of six keys. There are four function keys, and one up and one down arrow keys. The top left key that has a green circle and line is the ON/OFF key. The top right key is the back light. The bottom left is the Mode key, and the bottom right is the Enter key.

Turn the instrument on by pressing and releasing the ON/OFF button on the front of the instrument.

NOTE: Since the probe has not yet been prepared, the data on the display will be inaccurate.

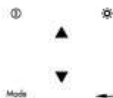

The light key is at the top right of the keypad. Pushing the **LIGHT** key will turn on or off the back light. The light will power off automatically after two minutes of non-use.

CHANGING THE TEMPERATURE UNITS

The YSI 550 DO Instrument can display the temperature units in either Fahrenheit or Celsius. To change the units that are displayed, turn the instrument on. Pressing both the down arrow keys and the mode key at the same time will switch the units between C or F.

CHOOSING THE RIGHT MEMBRANE

The YSI 5906 Standard Membrane Kit is supplied with the YSI 550 DO Instrument. This kit contains six cap membranes and a bottle of electrolyte solution. YSI recommends the 5906 membranes for all applications.

MEMBRANE CAP INSTALLATION

To install a new membrane cap on your YSI 550 dissolved oxygen probe:

Unscrew and remove the probe sensor guard.

1. Unscrew and remove the old membrane cap.
2. Thoroughly rinse the sensor tip with distilled or DI water.
3. xPrepare the electrolyte according to the directions on the solution bottle. Hold the membrane cap and fill it at least 1/2 full with the electrolyte solution.
4. Screw the membrane cap onto the probe moderately tight. A small amount of electrolyte should overflow.
5. Screw the probe sensor guard on moderately tight.

CAUTION: Do not touch the membrane surface.

HOW TO REPLACE THE DO PROBE TIP

In the YSI 559 dissolved oxygen module replacement kit YSI supplies a YSI 559 DO Sensor, a YSI 5906 membrane kit, the set screw that holds the sensor in place, a hex key wrench to help install the probe, and an instruction sheet.

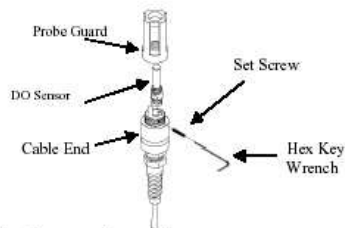

1. Remove probe guard.
2. **IMPORTANT:** Thoroughly dry the sensor so that no water enters the probe port when the sensor is removed.
3. Insert the long end of the hex key wrench into the small hole in the side of the DO sensor module. Turn the wrench counter clockwise and remove the screw. (You do not have to remove the screw all the way to release the sensor.)

4. Pull the DO sensor out of the module. The DO sensor is keyed, or has a flat side, so that it can not be removed improperly.
5. Insert the new probe. Make sure that the inside of the module, and the o-ring of the sensor are clean, with no contaminants, such as grease, dirt, or hair. The DO sensor is keyed, or has a flat side, so that it can not be installed improperly.
- 6a. **IF you did not remove the screw all the way in Step 3:** Use the hex key wrench to tighten the screw in properly, making sure that the screw does not stick out on either side of the DO sensor module.
- 6b. **IF you removed the screw all the way in Step 3:** Insert the set screw into the small hole in the side of the DO sensor module, and turn clockwise to retread.
7. The YSI 559 DO module is shipped dry. **Before using the YSI 550 with a new YSI 559 sensor, the protective membrane on the probe tip must be removed, the membrane cap must be filled with electrolyte solution and a new membrane must be installed.** Follow the instructions below to install the electrolyte solution and membrane.
8. Insert the new probe. Make sure that the inside of the module, and the o-ring of the sensor are clean, with no contaminants, such as grease, dirt, or hair. The DO sensor is keyed, or has a flat side, so that it can not be installed improperly.

CAUTION: Make sure that you do not cross-thread the screw. Use the hex key wrench to tighten the screw in properly, making sure that the screw does not stick out on either side of the cable end. The probe guard will not thread on properly and damage may result if the screw is allowed to stick out on either side of the cable end.

THE CALIBRATION PROCESS

Before you calibrate the YSI 550 DO Instrument complete the procedures discussed in **Section 2, Preparing the YSI 550** and **Section 3, Preparing the Probe**.

Note: While testing to EN-61000-4-6, Conducted RF Immunity, per Table A.1 of EN61326, Electrical Equipment for Measurement, Control and Laboratory Use, the YSI 550 exhibited an ERROR 8 message from 8.6 MHz 22.8 MHz at induced RF voltages of 3-Volts to 1-Volt RMS on the 25-foot probe cable. If you observe this interference please relocate the probe-cable away from heavy industrial equipment power and control cables or communications equipment cables which may be causing the interference.

To accurately calibrate the YSI 550, you will need to know the following information:

- The approximate salinity of the water you will be analyzing. Fresh water has a salinity of approximately zero. Seawater has a salinity of approximately 35 parts per thousand (ppt). If you are uncertain what the salinity of the sample water, use a YSI 30 Salinity-Conductivity-Temperature instrument to determine salinity.
- If you are going to calibrate in % saturation mode, you need to know the approximate altitude of the region where you are located.

1. Ensure that the sponge inside the instrument's calibration chamber is moist. Insert the probe into the calibration chamber.
2. Turn the instrument on by pressing the **ON/OFF** button on the front of the instrument. Wait for the dissolved oxygen and temperature readings to stabilize (usually 15 minutes is required after turning the instrument on).
3. To enter the calibration menu, use two fingers to press and release both the **UP ARROW** and **DOWN ARROW** keys at the same time.

TO CALIBRATE IN MG/L:

To switch between mg/L and percent saturation to be displayed as the oxygen readings units, press the Mode key. Either a "mg/L" or "%s" will be displayed on the right side of the screen.

4. Make sure that the DO reading (large display) is stable, then press the **ENTER** button. The YSI 550 DO instrument should now display **CAL** in the lower left of the display, the calibration value should be displayed in the lower right of the display and the current DO reading (before calibration) should be on the main display.
5. Make sure that the DO reading (large display) is stable, then press the **ENTER** button. The LCD will prompt you to enter the approximate salinity of the water you are about to analyze. You can enter any number from 0 to 40 parts per thousand (PPT) of salinity. Use the arrow keys to increase or decrease the salinity setting. When the correct salinity appears on the LCD (zero for fresh water), press the **ENTER** key. The instrument will return to normal operation.

Once the calibration process is complete, the only keys that will remain operational are the **MODE** key, the **LIGHT** key and the **ON/OFF** key. You can move back and forth from reading dissolved oxygen in the mg/L mode or the % air saturation mode by pressing the **MODE** key. If you are working in a dark area and have difficulty reading the LCD, press the **LIGHT** key to activate the back-light of the YSI 550. The **ON/OFF** key turns the instrument on or off.

For best results:

- Each time the YSI 550 DO Instrument is turned off, re-calibrate before taking measurements.
- Calibrate at a temperature within $\pm 10^{\circ}\text{C}$ of the sample temperature.

TO CALIBRATE IN % SATURATION:

To switch between mg/L and percent saturation to be displayed as the oxygen readings units, press the Mode key. Either a "mg/L" or "%" will be displayed on the right side of the screen.

4. If you are calibrating in % saturation mode, the LCD will prompt you to enter the local altitude in hundreds of feet. Use the arrow keys to increase or decrease the altitude.

EXAMPLE: Entering the number 12 here indicates 1200 feet.

6. When the proper altitude appears on the LCD, press the **ENTER** key. The YSI 550 DO Instrument should now display **CAL** in the lower left of the display, the calibration value should be displayed in the lower right of the display and the current DO reading (before calibration) should be on the main display.
7. Make sure that the DO reading (large display) is stable, then press the **ENTER** button. The LCD will prompt you to enter the approximate salinity of the water you are about to analyze. You can enter any number from 0 to 40 parts per thousand (PPT) of salinity. Use the arrow keys to increase or decrease the salinity setting. When the correct salinity appears on the LCD (zero for fresh water), press the **ENTER** key. The instrument will return to normal operation.

Once the calibration process is complete, the only keys that will remain operational are the **MODE** key, the **LIGHT** key and the **ON/OFF** key. You can move back and forth from reading dissolved oxygen in the mg/L mode or the % air saturation mode by pressing the **MODE** key. If you are working in a dark area and have difficulty reading the LCD, press and hold the **LIGHT** key to activate the back-light of the YSI 550. The **ON/OFF** key turns the instrument on or off.

For best results:

- Each time the YSI 550 DO Instrument is turned off, re-calibrate before taking measurements.
- Calibrate at a temperature within $\pm 10^{\circ}\text{C}$ of the sample temperature.

CONVERSION CHART

To Convert From	To	Equation
Feet	Meter	Multiply by 0.3048
Meter	Feet	Multiply by 3.2808399
Degrees Celsius	Degrees Fahrenheit	$(^{\circ}\text{C} \times 9/5) + 32$
Degrees Fahrenheit	Degrees Celsius	$(^{\circ}\text{F} - 32) \times 5/9$
Milligrams per liter (mg/L)	Parts per million (ppm)	Multiply by 1

YSI Incorporated



YSI Incorporated
 1725 Brannum Lane
 Yellow Springs, Ohio 45387 USA
 (800) 897 4151 (937) 767 7241
 Fax: (937) 767 9353
<http://www.ysi.com>
 e-mail: info@ysi.com

Item #655127
 Drawing #A655127
 Revision A
 March 2000



DISSOLVED OXYGEN TEST KIT

CODE 5860

For determining the dissolved oxygen content of water, this test kit uses the azide modification of the Winkler Method and employs a LaMotte Direct Reading Titrator in the final titration.

QUANTITY	CONTENTS	CODE
30 mL	*Manganous Sulfate Solution	*4167-G
30 mL	*Alkaline Potassium Iodide Azide	*7166-G
30 mL	*Sulfuric Acid, 1:1	*6141WT-G
60 mL	*Sodium Thiosulfate, 0.025N	*4169-H
30 mL	Starch Indicator Solution	4170WT-G
1	Direct Reading Titrator, 0 - 10	0377
1	Titration Tube, 20 mL, w/cap	0299
1	Bottle, Water Sampling, 60 mL, glass	0688-DO

***WARNING:** Reagents marked with a * are considered hazardous substances. Material Safety Data Sheets (MSDS) are supplied for these reagents. For your safety, read label and accompanying MSDS before using.

To order individual reagents or test kit components, use the specified code number.

NOTE: A Check Standard is needed to perform an "EPA Accepted" test.

DIRECT READING TITRATOR INSTRUCTIONS

1. Fill the titration tube to 20 mL line with sample water.
2. Add the reagents as specified in the test procedure. Cap the tube with the special titration tube cap. Mix by swirling gently.
3. Depress the plunger of the Titrator to expel air.
4. Insert the Titrator into the plastic fitting of the titrating solution bottle.

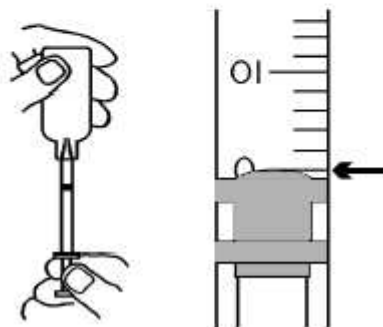

5. To fill the Titrator invert the bottle and slowly withdraw the plunger until the bottom of the plunger is opposite the zero mark on the scale.

NOTE: A small air bubble may appear in the Titrator barrel. Expel the bubble by partially filling the barrel and pumping the titrating solution back into the inverted reagent container. Repeat this pumping action until the bubble disappears.

6. Turn the bottle right-side-up and remove the Titrator.
7. Insert the tip of the Titrator into the opening of the titration tube cap. Slowly depress the plunger to dispense the titrating solution. Gently swirl tube to mix. A slight rotating or twisting motion may permit the plunger to move more smoothly.
8. Continue adding the titrating solution until the specified color change occurs. If no color change occurs by the time the plunger tip reaches the bottom of the scale, refill the Titrator to the zero mark. Continue the titration. Include both titration amounts in the final test result.
9. Read the test result directly from the scale opposite the bottom of the plunger tip.
10. If no additional tests are to be made, discard the titrating solution in the Titrator. Thoroughly rinse the Titrator and the titration tube.

NOTE: The plunger tip should periodically be coated with silicon grease.

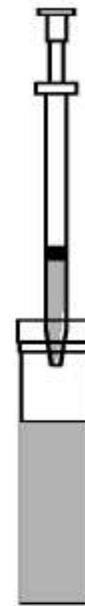

COLLECTION & TREATMENT OF THE WATER SAMPLE

Steps 1 through 4 below describe proper sampling technique in shallow water. For sample collection at depths beyond arm's reach, special water sampling apparatus is required (e.g., the LaMotte Water Sampling Chamber, Code 1060; Model JT-I Water Samplers, Code 1077; Water Sampling Outfit, Code 3103; or Code 3-0026 Water Sampling Bottle).

1. To avoid contamination, thoroughly rinse the Water Sampling Bottle (0688-DO) with sample water.
2. Tightly cap the bottle and submerge to the desired depth. Remove cap and allow the bottle to fill.
3. Tap the sides of the submerged bottle to dislodge any air bubbles clinging to the inside. Replace cap while the bottle is still submerged.
4. Retrieve bottle and examine it carefully to make sure that no air bubbles are trapped inside. Once a satisfactory sample has been collected, proceed immediately with Steps 5 & 6 to "fix" the sample.

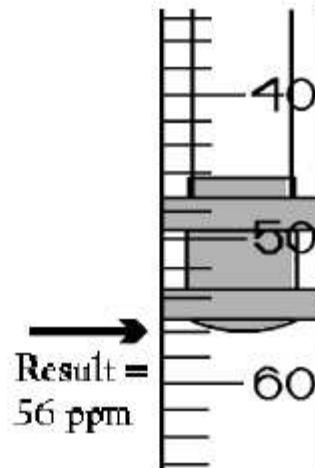

NOTE: Be careful not to introduce air into the sample while adding the reagents in Steps 5 & 6. Simply drop the reagents into sample. Cap carefully, and mix gently.

5. Add 8 drops of *Manganous Sulfate Solution (4167) and 8 drops of *Alkaline Potassium Iodide Azide (7166). Cap and mix by inverting several times. A precipitate will form. Allow the precipitate to settle below the shoulder of the bottle before proceeding.
6. Add 8 drops of *Sulfuric Acid, 1:1 (6141WT). Cap and gently mix until the precipitate has dissolved. A clear-yellow to brown-orange color will develop, depending on the oxygen content of the sample.

NOTE: Following the completion of Step 6, contact between the water sample and the atmosphere will not affect the test result. Once the sample has been "fixed" in this manner, it is not necessary to perform the actual test procedure immediately. Thus, several samples can be collected and "fixed" in the field, and then carried back to a testing station or laboratory where the test procedure is to be performed.

MATERIAL SAFETY DATA SHEET

LaNOTTE COMPANY
PO BOX 920 - CHESTERTOWN - MARYLAND - 21620
TELEPHONE # FOR INFORMATION 410-778-3100

24 Hour Emergency Number (CHEM-TEL) 800-255-3924

1. PRODUCT IDENTIFICATION
Sodium Thiosulfate, 025 N Code Nr. 4169

2. HAZARDOUS INGREDIENTS

NAME	CAS #	YSCA #	%	PEL	ID
Sodium Hydroxide	1310-73-2		<0.1	50%	Seh

3. NON-HAZARDOUS INGREDIENTS EXCEPT WATER (7732-18-5)

NAME	CAS #	%
Sodium Thiosulfate, 5-hydrate	10102-17-7	<1
Water to 100%		

4. PHYSICAL DATA

Appearance: Clear Colorless Liquid

Solubility in Water: Soluble	Color: None	Boiling Point: ca. 100 deg C	Melt. Point: Unknown
Vapor Pressure: <1 @ 20 deg C	Vapor Density: <1 (Air=1)	pH: 11	

5. FIRE AND EXPLOSION DATA

Flash Point (method used): N/A Flammable Limit: LEL: N/A UEL: N/A

Extinguishing Media: Not a fire hazard

HMS Hazard: Health - 1 Flammability - 0 Reactivity - 0 Scale: 3 = Extreme, 2 = High, 1 = Moderate, 0 = Slight, -1 = Low

Special Fire Fighting Procedures: N/A

Unusual Fire & Explosion Hazard: N/A

6. REACTIVITY DATA

Stability: Conditions to avoid: Heat, light
<input checked="" type="checkbox"/> Stable <input type="checkbox"/> Unstable
Incompatibility (Materials to avoid): N/A
Hazardous Decomposition Products: N/A

7. HEALTH HAZARD DATA

Toxicity: Non-toxic

Primary Route of Entry: Inhalation Skin Ingestion N/A Carcinogenicity: None NTP OSHA IARC

Other Health Related Comments:

Target Organ: N/A

Signs and symptoms of exposure: Large doses by mouth can cause GI irritation. May cause skin irritation.

Medical Condition Aggravated by Exposure: N/A

8. EMERGENCY FIRST AID PROCEDURES

Eye Contact: Flush with water for 15 minutes.

Ingestion: Drink plenty of water. Consult a physician.

Inhalation: N/A

Skin Contact: Flush with water. Wash with soap and water.

9. SPILL AND DISPOSAL PROCEDURES

Spill and Leak: Neutralize with vinegar or other dilute acid and mop up.

Disposal: Neutralize with dilute acid and wash down drain with copious water.

10. PRECAUTIONARY MEASURES

In Handling: Gloves Eye Protection N/A Other:

Ventilation: Natural Mechanical Respiratory Protection

Hygiene Practices: Avoid contact with eyes or skin.

11. SPECIAL PRECAUTIONS

Store away from heat and light.

DATE: 11/1/03 The above information is believed to be correct but does not claim to be all inclusive and should be used only as a guide.

This is a toxic chemical subject to reporting requirements of section 315 of HCSRA and 40 CFR 372.

MATERIAL SAFETY DATA SHEET

LAMOTTE COMPANY
PO BOX 329 - CHESTERTOWN - MARYLAND - 21620
TELEPHONE # FOR INFORMATION 410-778-3100

24 Hour Emergency Number (CHEM-TEL) 800-255-3924

1. PRODUCT IDENTIFICATION					
Alkaline Potassium Iodide Azide			<i>Code No. 7166</i>		
2. HAZARDOUS INGREDIENTS					
NAME	CAS #	FSCL #	%	PEL	HP
Potassium Hydroxide	1310-58-1		68 - 70	C 2 mg/cubic m	C 2 mg/cubic m
Sodium Azide	26638-22-8		<1	C 0.1 ppm (skin) as HNS	C 0.3 mg/cubic m as HNS
Potassium Iodide	7681-11-4		14	NE	NE
3. NON-HAZARDOUS INGREDIENTS EXCEPT WATER (7732-18-5)					
NAME	CAS #	%			
Water to 100%					
4. PHYSICAL DATA					
Appearance: Clear Colorless Liquid					
Solubility in Water: Soluble		Odor: None		Boiling Point: Unknown	
Vapor Pressure: Unknown		Vapor Density: Unknown		Melting Point: N/A	
5. FIRE AND EXPLOSION DATA					
Flash Point (method used): N/A			Flammable Limit: LEL: N/A		UEL: N/A
Extinguishing Media: Not a fire hazard					
HMS Hazard: Health - 3 Flammability - 1 Reactivity - 2 Scale: 4 = Extreme, 3 = High, 2 = Moderate, 1 = Slight, 0 = Low					
Special Fire Fighting Procedures:					
Wear self contained breathing apparatus and protective clothing to prevent inhalation and contact with eyes.					
Unusual Fire & Explosive Hazards:					
Violent exothermic reaction occurs with water. May produce enough heat to ignite combustibles. Can react with metals to produce hydrogen, forming explosive mix with air.					
6. REACTIVITY DATA					
Stability: Conditions to avoid: Heat					
<input checked="" type="checkbox"/> Stable: Incompatibility (Materials to avoid): Strong acids, metals					
<input type="checkbox"/> Unstable: Hazardous Decomposition Products: Hydrogen gas					
7. HEALTH HAZARD DATA					
Toxicity: oral LD50: 393 mg/kg for potassium hydroxide, 27 mg/kg for sodium azide acid					
Primary Route of Entry: <input type="checkbox"/> Inhalation <input checked="" type="checkbox"/> Skin <input type="checkbox"/> N/A <input type="checkbox"/> Ingestion <input checked="" type="checkbox"/> None <input type="checkbox"/> NTP <input type="checkbox"/> CASH <input type="checkbox"/> EAC					
Other Health Related Comments:					
Target Organs: Corrosive to all body parts, eyes, skin.					
Signs and symptoms of exposure: Severe burns, may be fatal if swallowed					
Medical Condition Aggravated by Exposure: N/A					
8. EMERGENCY FIRST AID PROCEDURES					
Eye Contact: Immediately flush with water for 15 minutes. Get medical attention immediately.					
Ingestion: Do not induce vomiting. Rinse out mouth, drink plenty of water and call a doctor immediately.					
Inhalation: Remove to fresh air.					
Skin Contact: Immediately flush with water while removing affected clothing and rinse skin thoroughly for 15 minutes. Consult physician.					
9. SPILL AND DISPOSAL PROCEDURES					
Spill and Leak: Neutralize by carefully and slowly adding dilute hydrochloric acid (conc. 6M or less) to pH 7. Collect waste liquid. Dispose of as follows:					
Disposal: Small amt. <5 gal. Flush neutralized waste to drain with water. Large amt. Sodium azide can react with metal - such as copper pipes - to form shock or friction sensitive metal azides (explosive). Dispose of large amt. as hazardous waste, according to federal, state and local regulations.					
10. PRECAUTIONARY MEASURES					
In Handling: <input checked="" type="checkbox"/> Gloves <input checked="" type="checkbox"/> Eye Protection <input type="checkbox"/> N/A <input checked="" type="checkbox"/> Other: Lab Coat					
Ventilation: <input checked="" type="checkbox"/> Natural <input type="checkbox"/> Mechanical <input type="checkbox"/> Respiratory Protection					
Work Hygiene Practices: Avoid contact with skin and clothing. Use nitrile gloves, goggles, face shield, protective clothing					
11. SPECIAL PRECAUTIONS					
Store away from incompatible items (acids, metals)					
DATE: 11/1/03					

The above information is believed to be correct but does not claim to be all inclusive and should be used only as a guide.

* This is a toxic chemical subject to reporting requirements of section 315 of RCRA and 49 CFR 171.

MATERIAL SAFETY DATA SHEET

LaMOTTE COMPANY
PO BOX 920 - CHESTER TOWN - MARYLAND - 21620
TELEPHONE # FOR INFORMATION 410-778-3100

24 Hour Emergency Number (CHEM-TEL) 800-255-3924

1. PRODUCT IDENTIFICATION

Manganous Sulfate Solution Code Nr. **4167**

2. HAZARDOUS INGREDIENTS

NAME	CAS #	TSU #	%	PEL	IDL
Manganous Sulfate monohydrate	1034-96-2	7752-87-7	36	3 mg/cubic m as Mn	0.9 mg/cubic m as Mn

3. NON-HAZARDOUS INGREDIENTS EXCEPT WATER (7732-18-5)

NAME	CAS #	%
Water to 100%		

4. PHYSICAL DATA

Appearance: Clear Pink Liquid
Solubility in Water: Soluble
Vapor Pressure: <1 @ 20 deg C
Vapor Density: <1 (Air=1) pH: 3

5. FIRE AND EXPLOSION DATA

Flash Point (method used): N/A
Extinguishing Media: Not a fire hazard
HMIS Hazards: Health - 1 Flammability - 0 Reactivity - 0 Scale: 4 = Extreme, 3 = High, 2 = Moderate, 1 = Slight, 0 = Low
Special Fire Fighting Procedures: N/A
Critical Fire & Explosion Hazards: N/A

6. REACTIVITY DATA

Stability: Conditions to avoid: N/A
 Stable Incompatibility (Materials to avoid): N/A
 Unstable
Hazardous Decomposition Products: N/A

7. HEALTH HAZARD DATA

Toxicity: Unknown
Primary Route of Entry: Inhalation Skin Eye Ingestion N/A
Carcinogenicity: None NTP
 OSHA IARC
Other Health Related Comments: Manganese investigated as a tumorigen, mutagen, reproductive effector.
Target Organ: N/A
Signs and symptoms of exposure: May irritate eyes and skin. Harmful if swallowed.
Medical Condition Aggravated by Exposure: N/A

8. EMERGENCY FIRST AID PROCEDURES

Eye Contact: Immediately flush with water for 15 minutes. Consult a physician.
Ingestion: Induce vomiting immediately. Consult a physician.
Inhalation: N/A
Skin Contact: Flush thoroughly with water. Remove affected clothing and wash skin with soap and water. Consult physician.

9. SPILL AND DISPOSAL PROCEDURES

Spill and Leak: Mop up carefully and hold for disposal.
Disposal: Small quantity: Flush down drain with excess water. Large quantity: Containerize and dispose of as hazardous waste according to federal, state and local regulations.

10. PRECAUTIONARY MEASURES

In Handling: Gloves Eye Protection N/A Dribof: Lab Coat
Ventilation: Natural Mechanical Respiratory Protection

11. SPECIAL PRECAUTIONS

DATE: 11/1/03 This above information is believed to be correct but does not claim to be all inclusive and should be used only as a guide.
This is a toxic chemical subject to reporting requirements of section 315 of HCSRA and 49CFR372.

MATERIAL SAFETY DATA SHEET

LANOTTE COMPANY
PO BOX 929 - CHESTERTOWN - MARYLAND - 21620
TELEPHONE # FOR INFORMATION 410-778-3100

24 Hour Emergency Number (CHEM-TEL) 800-255-3924

1. PRODUCT IDENTIFICATION

Sulfuric Acid, 1:1 Code Nr. 6141

2. HAZARDOUS INGREDIENTS

NAME	CAS #	FSLS #	%	PEL	IDL
Sulfuric Acid	7664-93-9		64	1 mg/cubic m	1 mg/cubic m

3. NON-HAZARDOUS INGREDIENTS EXCEPT WATER (7732-18-5)

NAME	CAS #	%
Water to 100%		

4. PHYSICAL DATA

Appearance: Colorless Liquid
Solubility in Water: Soluble
Vapor Pressure: <1 @ 20 deg C
Boiling Point: > 100 deg C
Melting Point: N/A

Specific Gravity: >1 (Aq=1)
pH: <1

5. FIRE AND EXPLOSION DATA

Flash Point (method used): N/A
Flammable Limit: LEL: N/A
UEL: N/A

Extinguishing Media: Dry chemical or CO2, not water

HMS Hazard: Health - 3
Flammability - 1
Reactivity - 2
Scale: 4 = Extreme, 3 = High, 2 = Moderate, 1 = Slight, 0 = Low

Special Fire Fighting Procedures:
Wear protective equipment and self-contained breathing apparatus.

Unusual Fire & Explosion Hazard:
A violent exothermic reaction occurs with water. Reacts with metals to form flammable, explosive hydrogen gas.

6. REACTIVITY DATA

Stability: Conditions to avoid: Moisture

Incompatibility (Materials to avoid):
Water, metals, organic or combustible materials, and strong bases.

Hazardous Decomposition Products: SO2, hydrogen gas

7. HEALTH HAZARD DATA

Toxicity: oral LD50: 2140 mg/kg for sulfuric acid

Primary Route of Entry: Inhalation Skin N/A None NTP
 Ingestion N/A OSHA IARC

Other Health Related Comments:

Target Organs: Corrosive to all body parts, skin.

Signs and symptoms of exposure:
Severe burns. Ingestion may be fatal. Inhalation can cause coughing, chest pains, damage to lungs.

Medical Condition Aggravated by Exposure: N/A

8. EMERGENCY FIRST AID PROCEDURES

Eye Contact: Immediately flush with water for 15 minutes. Call a doctor immediately.

Ingestion: Do not induce vomiting. Rinse mouth, drink plenty of water. Call a doctor immediately.

Inhalation:
Remove to fresh air. Give artificial respiration if not breathing. If breathing is difficult, give oxygen.

Skin Contact:
Immediately flush with water for 15 minutes while removing affected clothing. Consult physician.

9. SPILL AND DISPOSAL PROCEDURES

Spill and Leak:
Wear gloves & eye protection. Cover spill with sodium bicarbonate or soda ash/calcium hydroxide mixture. Mix and carefully add water to form slurry, avoiding heat, spattering, and fumes. Scoop up and flush to drain with excess water.

Disposal:
Add very slowly with stirring to a large volume of soda ash & calcium hydroxide. Pour neutralized solution down drain with excess water. Dispose according to federal, state and local regulations.

10. PRECAUTIONARY MEASURES

In Handling: Gloves Eye Protection N/A Other: Lab Coat

Ventilation: Natural Mechanical Respiratory Protection

Work Hygienic Practices: Avoid contact with skin and clothing and inhalation of vapor.

11. SPECIAL PRECAUTIONS

Store away from incompatible items (bases, metal powders, combustible materials).

DATE: 11/103

The above information is believed to be correct but does not claim to be all inclusive and should be used only as a guide.

This is a toxic chemical subject to reporting requirements of section 315 of EPCRA and 48CFR372.